

This drawing and any information or descriptive material set out on it are the confidential and copyright property of bulamyan@gmail.com and may not be copied, reproduced, transmitted or communicated to a third party, or used for any purpose without the written permission of bulamyan@gmail.com

bulamyan@gmail.com

RANGE	0.5-3	>3-6	>6-30	>30-120	>120-400	>400-1000	>1000-3000
ALLOWANCE	±0.1	±0.1	±0.2	±0.3	±0.5	±0.8	±1.2

SYM	REVISION RECORD	ISSUE No.	DATE	DR
△				
△				

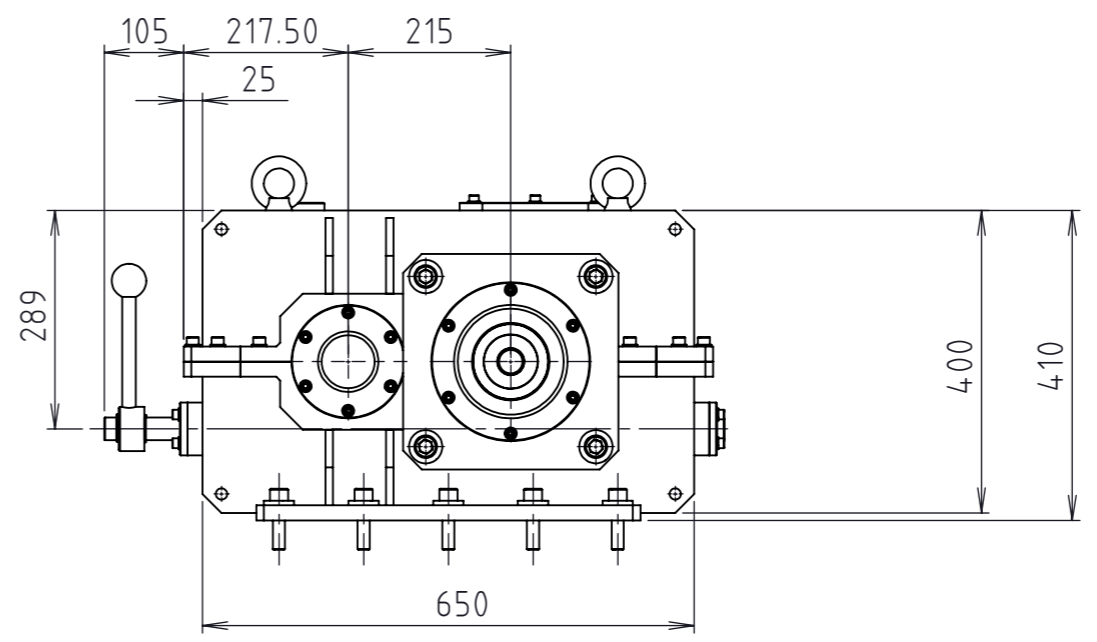
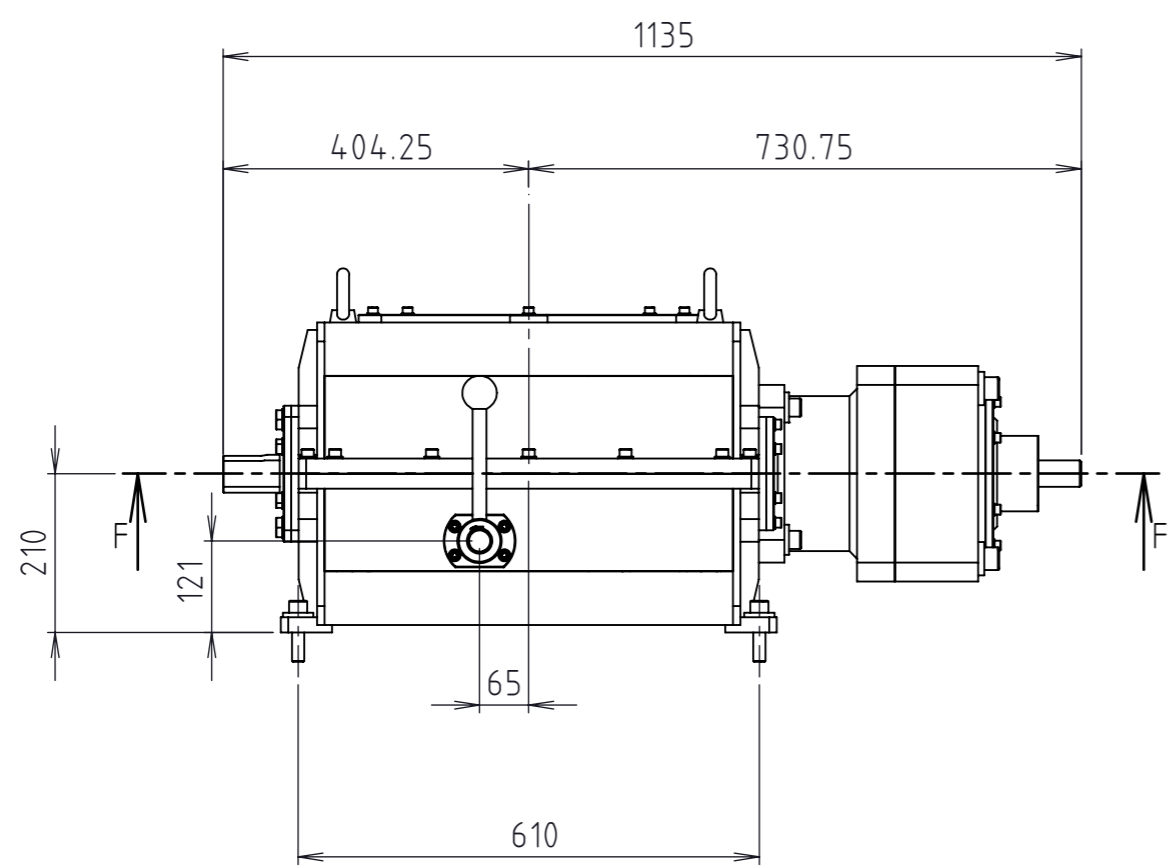
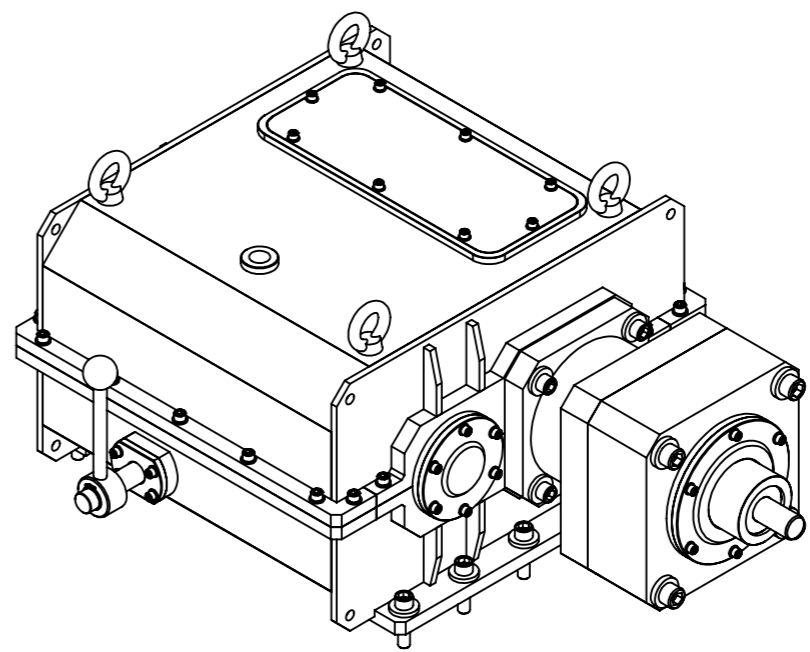
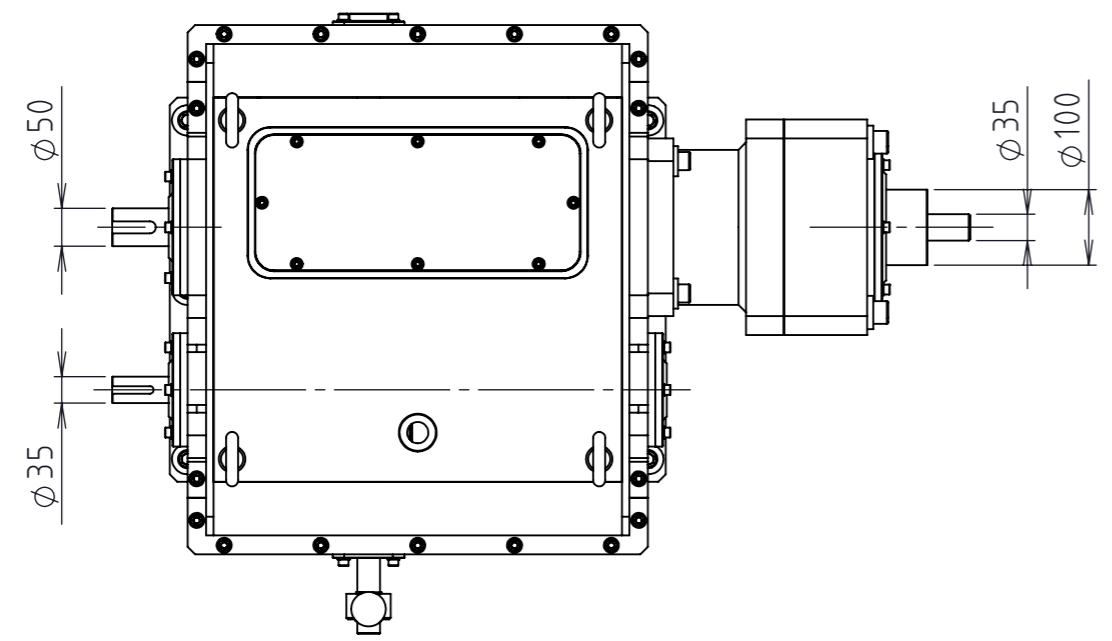

DESIGN	DRAWN	CHECKED	APPR.	TITLE :	GENERAL TOL	LINEAR	ISO 2768-M
				TM001-10-00	ANGULAR	±0.5°	
				OVERAL DIM	EDGES	ISO 13715	
BULAM YAN	BULAM YAN			Drawing No.	MATERIAL :	STEEL	
				JOB ID / PRODUCTION CODE:			QTY : 1
					SCALE = 1:15	UNIT = mm	FABRICATION PART
							A3

REMOVE ALL BURRS AND SHARP EDGES (UNSPECIFIED) TO C0.15-C0.3 MAX!

This drawing and any information or descriptive material set out on it are the confidential and copyright property of bulamyan@gmail.com and may not be copied, reproduced, transmitted or communicated to a third party, or used for any purpose without the written permission of bulamyan@gmail.com

bulamyan@gmail.com

RANGE	0.5-3	>3-6	>6-30	>30-120	>120-400	>400-1000	>1000-3000
ALLOWANCE	±0.1	±0.1	±0.2	±0.3	±0.5	±0.8	±1.2

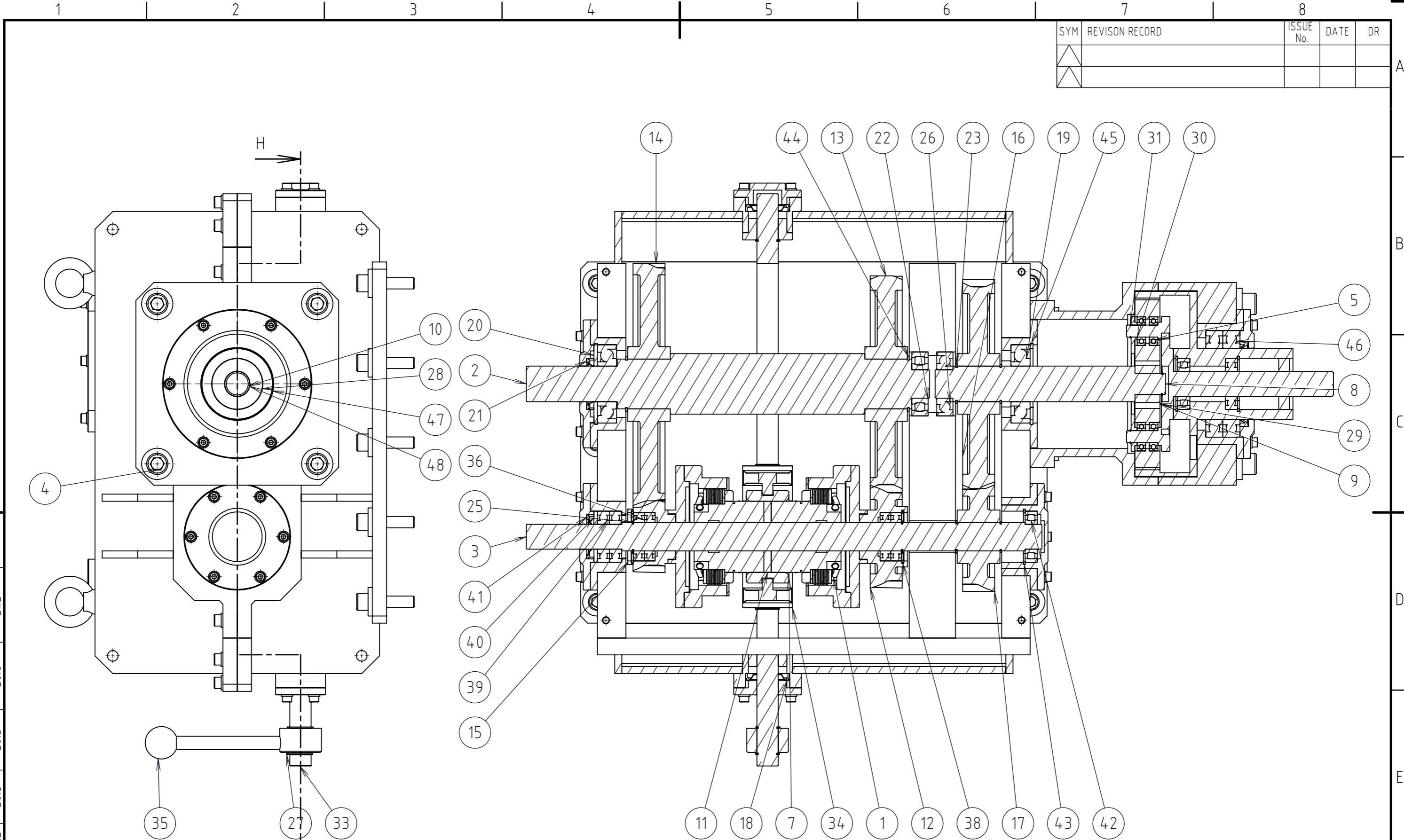

SYM	REVISION RECORD	ISSUE No.	DATE	DR
△				
△				

DESIGN	DRAWN	CHECKED	APPR.	TITLE :	GENERAL TOL	LINEAR	ISO 2768-M
				TM001-10-00	ANGULAR	±0.5°	
				SECTION	EDGES	ISO 13715	
BULAM YAN	BULAM YAN			Drawing No.	MATERIAL :	STEEL	
				JOB ID / PRODUCTION CODE:			
				SCALE = 1:15	UNIT = mm	FABRICATION PART	QTY : 1
							A3

⦿ REMOVE ALL BURRS AND SHARP EDGES (UNSPECIFIED) TO C0.15-C0.3 MAX!

This drawing and any information or descriptive material set out on it are the confidential and copyright property of bulamyan@gmail.com and may not be copied, reproduced, transmitted or communicated to a third party, or used for any purpose without the written permission of bulamyan@gmail.com

bulamyan@gmail.com

RANGE	0.5-3	>3-6	>6-30	>30-120	>120-400	>400-1000	>1000-3000
ALLOWANCE	±0.1	±0.1	±0.2	±0.3	±0.5	±0.8	±1.2

ITEM NO.	PART NUMBER	QTY
1	TM001-30-00	2
2	TM001-10-01	1
3	TM001-10-02	1
4	TM001-20-00	1
5	DIN 625 - 6203	8
6	PARALLEL KEY A10 x 8 x 25 DIN 6885	4
7	TM001-30-01	1
8	TM001-10-04	1
9	DIN - SPUR GEAR 3M 20T 20PA 35FW - S20A75H50L30R1	1
10	TM001-10-07	1
11	TM001-10-10	1
12	DIN - LH HELICAL GEAR 4.75M 28T 10HA 20PA 45FW - 28C75H60L40R1	1
13	DIN - RH HELICAL GEAR 4.75M 61T 10HA 20PA 45FW - 61C85H60L50R1	1
14	DIN - RH HELICAL GEAR 4.75M 70T 10HA 20PA 45FW - 70C85H60L50R1	1
15	DIN - LH HELICAL GEAR 4.75M 19T 10HA 20PA 45FW - 19C75H75L40R1	1
16	DIN - RH HELICAL GEAR 4.75M 59T 10HA 20PA 45FW - 59C85H60L50R1	1
17	DIN - LH HELICAL GEAR 4.75M 30T 10HA 20PA 45FW - 30C75H60L40R1	1
18	SEAL AS 40x62x10 DIN3760	2
19	DIN 628 - 7310B	2
20	TM001-10-09	1
21	SEAL AS 50x72x10 DIN3760	1
22	DIN 635 - 20308	1
23	CIRCLIP DIN 471 - 50 x 2	2
24	Parallel key A16 x 10 x 45 DIN 6885	1
25	CIRCLIP DIN 471 - 40x1.75	4
26	DIN 628 - 7308B	1
27	CIRCLIP DIN 471 - 30 x 1.5	7
28	DIN - INTERNAL SPUR GEAR 3M 79T 20PA 35FW - S79S2600D 1AF	1
29	DIN - SPUR GEAR 3M 29T 20PA 35FW - S29A75H50L40N	4
30	TM001-10-06	1
31	CIRCLIP DIN 471 - 17 x 1	4
32	PARALLEL KEY A12 x 8 x 40 DIN 6885	3
33	TM001-10-03	1
34	TM001-10-05	1
35	LEVER HAND DIN 99	1
36	DIN 625 - 6008	4
37	PARALLEL KEY A10 x 12 x 56 DIN 6885	2
38	CIRCLIP DIN 472 - 72 x 2.5	2
39	DIN 625 - 6207	3
40	TM001-10-11	1
41	SEAL AS 35x62x10 DIN3760	1
42	DIN 635 - 20207	2
43	CIRCLIP DIN 472 - 75 x 2.5	3
44	CIRCLIP DIN 471 - 70 x 2.5	2
45	Circlip DIN 472 - 110 x 4	1
46	DIN 625 - 6020	2
47	SEAL AS 100x120x12 DIN3760	1
48	TM001-10-12	1

SYM	REVISION RECORD	ISSUE No.	DATE	DR
△				
△				

				<table border="1"> <tr><td>GENERAL TOL</td><td>LINEAR</td><td>ISO 2768-M</td></tr> <tr><td></td><td>ANGULAR</td><td>±0.5°</td></tr> <tr><td></td><td>EDGES</td><td>ISO 13715</td></tr> </table>		GENERAL TOL	LINEAR	ISO 2768-M		ANGULAR	±0.5°		EDGES	ISO 13715
GENERAL TOL	LINEAR	ISO 2768-M												
	ANGULAR	±0.5°												
	EDGES	ISO 13715												
DESIGN	DRAWN	CHECKED	APPR.	TITLE : TM001-10-00										
				----- BOM TABLE -----										
BULAM YAN				MATERIAL : STEEL										
BULAM YAN				Drawing No.										
JOB ID / PRODUCTION CODE:				QTY : 1										
SCALE = 1:15		UNIT = mm		FABRICATION PART										
				A3										

REMOVE ALL BURRS AND SHARP EDGES (UNSPECIFIED) TO C0.15-C0.3 MAX!

A
B
C
D
E
F
Sheet: 3/3